

*the heatmaster*

**Riscaldatori PTC Classe I per Scaldasalviette / Class I PTC heaters for Towel Rails**



Dal 1978 HT SpA si è distinta per la grande capacità di proporre soluzioni tecniche innovative nel settore del riscaldamento domestico.

Nel corso degli anni ha saputo affinare la qualità del proprio prodotto, grazie anche alla crescente richiesta di applicazioni affidabili e sicure.

Proprio per questo HT SpA è stata una delle prime aziende del settore a ricevere l'omologazione ISO29002, recentemente aggiornata secondo ISO9001:Vision, seguita dalle approvazioni di prodotto VDE e UL/CSA.

Anche per il futuro intendiamo proseguire nell'impegno intrapreso, per coniugare una sicura crescita con il mantenimento della flessibilità necessaria per dare ai nostri clienti la massima soddisfazione con un unico obiettivo: "fornire il calore giusto nel posto giusto".

*From the outset HT has established itself in the market by proposing innovative solutions for the domestic heating which has helped us to put the Company where it is today as market leader.*

*Over the years HT SpA have been able to constantly improve on the quality of it's products spurred on by the growing demand for reliable and safe applications.*

*This is the reason why HT SpA was one of the first companies in this sector with a Quality System approved in accordance to ISO 29002, recently up-graded to ISO9001:2000 Vision, followed by the products approvals according to VDE and UL/CSA.*

*In the future it is HT SpA's intention to continue to pursue this course of combining a steady growth with the flexibility that will give our customers " the right heat in the right place".*

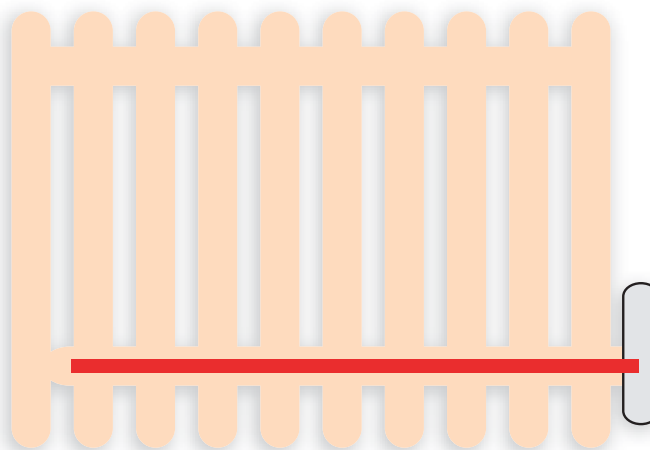



# RISCALDATORI PTC PER SCALDASALVIETTE/PTC HEATERS FOR TOWEL RAILS

ISOLAMENTO ELETTRICO: Classe I  
 INDICE DI PROTEZIONE: IP64  
 MONTAGGIO: Verticale o orizzontale

ELECTRIC INSULATION: Class I  
 PROTECTION RATE: IP64  
 MOUNTING: Vertically or horizontally

La tecnologia PTC rende inutile qualsivoglia dispositivo di sicurezza interno, poiché la sua caratteristica peculiare è quella di non bruciare nemmeno se viene a mancare il liquido all'interno dello scaldasalviette. In questi casi, infatti, il riscaldatore PTC riduce automaticamente il proprio assorbimento di potenza finché non vengono ripristinate le corrette condizioni di utilizzo

The PTC technology eliminates the need for any internal safety device as its distinctive characteristic is to self-reduce its power absorption in abuse conditions, i.e. should the towel rail run empty, thus avoiding the risk of damages to the heating element until the correct working conditions are restored.

## RISCALDATORI CON CAVO E SPINA HEATERS WITH CABLE AND PLUG

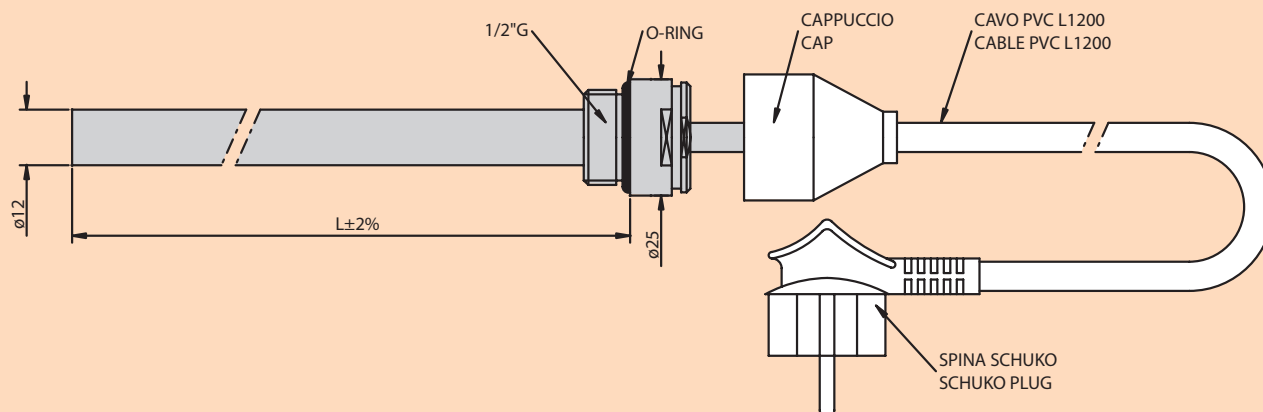

Tipo 1: Cappuccio, cavo e spina bianchi  
 Type 1: White cap, cable and plug



Tipo 2: Cappuccio cromato, cavo e spina grigi  
 Type 2: Chrome cap, grey cable and plug

CODICI TIPO 1 PART NOS. TYPE 1	CODICI TIPO 2 PART NOS. TYPE 2	L (mm)	W	V
PT92473	PT95554	150	100	230
PT92475	PT95555	150	150	230
PT92476	PT95556	250	200	230
PT92478	PT95557	350	300	230
PT92480	PT95558	350	400	230
PT92481	PT95559	415	500	230
PT92482	PT95560	600	600	230
PT92483	PT95561	600	700	230
PT92485	PT95562	710	900	230
PT92486	PT95563	710	1000	230
PT92487	PT95564	920	1250	230
PT92488	PT95565	1095	1500	230

Tutti i modelli presenti in questa tabella sono **disponibili a magazzino**  
 All the models shown in the above chart are **in stock**.

## RISCALDATORI CON INTERRUTTORE LUMINOSO ON-OFF HEATERS WITH LUMINOUS ON-OFF SWITCH

ISOLAMENTO ELETTRICO: Classe I  
INDICE DI PROTEZIONE: IP54  
MATERIALE DEL GUSCIO: ABS V0 (autoestinguente)  
MONTAGGIO: Verticale o orizzontale

ELECTRIC INSULATION: Class I  
PROTECTION RATE: IP54  
SHELL MATERIAL: ABS V0 (self-extinguishing)  
MOUNTING: Vertically or horizontally

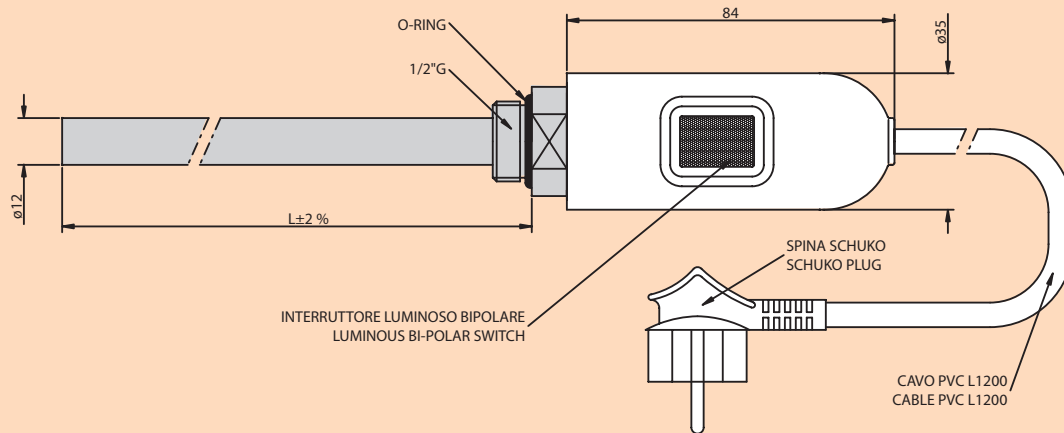

Tipo 1: Interruttore bianco (RAL9010), cavo e spina bianchi  
Type 1: White switch (RAL9010), white cable and plug



Tipo 2: Interruttore grigio (RAL9006), cavo e spina grigi  
Type 2: Grey switch (RAL9006), grey cable and plug

CODICI TIPO 1 PART NOS. TYPE 1	CODICI TIPO 2 PART NOS. TYPE 2	L (mm)	W	V
PT95432	PT95441	150	100	230
PT95433	PT95442	150	150	230
PT95434	PT95443	250	200	230
PT95435	PT95444	300	300	230
PT95436	PT95445	350	400	230
PT95437	PT95446	415	500	230
PT95438	PT95447	600	600	230
PT95439	PT95448	600	700	230
PT95440	PT95449	710	900	230
PT95441	PT95450	710	1000	230
PT95442	PT95451	920	1250	230
PT95443	PT95452	1095	1500	230

Tutti i modelli presenti in questa tabella sono **disponibili a magazzino**  
All the models shown in the above chart are **in stock**.

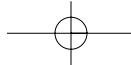

**RISCALDATORI CON FASTON DA ABBINARE A CONTROLLI ELETTRONICI DI TEMPERATURA**  
**HEATERS WITH FAST-ONS FOR ELECTRONIC TEMPERATURE CONTROLS**

ISOLAMENTO ELETTRICO: Classe I  
 INDICE DI PROTEZIONE: IP64  
 MONTAGGIO: Verticale o orizzontale

*ELECTRICAL INSULATION: Class I*  
*PROTECTION RATE: IP64*  
*MOUNTING: Vertically or horizontally*

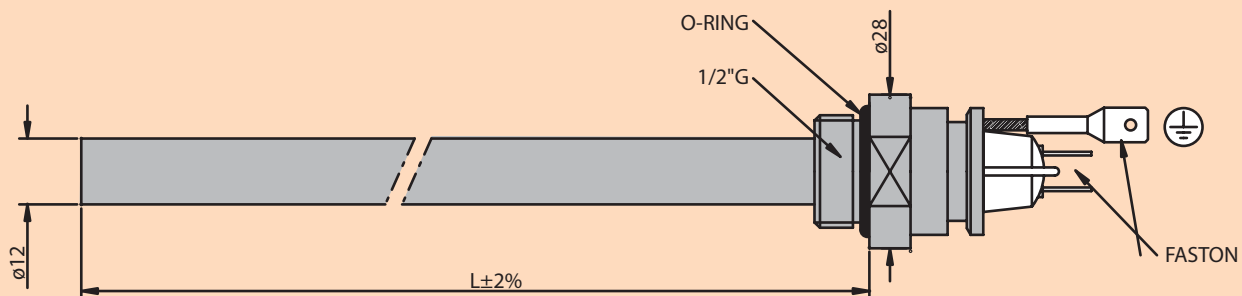

L (mm)	W	V
150	100	230
150	150	230
250	200	230
350	300	230
350	400	230
415	500	230
600	600	230
600	700	230
710	900	230
710	1000	230
920	1250	230
1095	1500	230

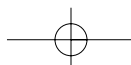



## ACCESSORI / ACCESSORIES

A completamento della propria offerta di resistenze e controlli, HT SpA mette a disposizione dei suoi clienti anche utili accessori: Controlli elettronici della temperatura ambiente o del fluido scaldante; Raccordi a "T" cromati o verniciati bianchi per i sistemi misti; Tappi ciechi cromati o verniciati bianchi ed altro ancora.

*To complete its range of products for towel rails, HT SpA can also supply its customers with useful accessories such as: Electronic controls operating either on the room or on the heating fluid temperature; White-coated or chrome-plated "T" pieces for dual-fuel systems; White-coated or chrome-plated blanking plugs and more.*



Controlli elettronici analogici o digitali, Serie TH006 / *Analogic and digital electronic controls, Series Th006*



Tappo cieco bianco  
*White-coated blanking plug*

"T" bianco + O-Ring  
*White-coated "T" + O-Ring*



Tappo cromato

"T" cromato + O-Ring  
*Chrome-plated blanking plug Chrome-plated "T" + O-Ring*

## IMBALLI PERSONALIZZATI CUSTOMISED PACKAGING

Un'altra interessante opzione offerta da HT è quella del kit per imballo personalizzato, che riunisce in un'unica scatola i prodotti richiesti.

*Another interesting option offered by HT is the customised packaging: all your required products put together in one single carton.*





ADV STUDIOGENIUS



ARTIGIANICHE CONEGLIANO



# the heatmaster

2007C/PTCLI

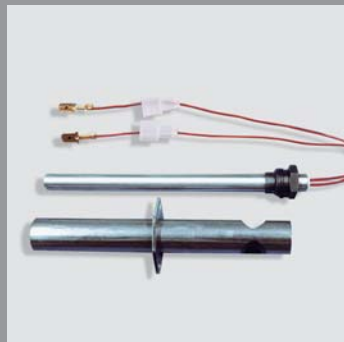

**HT S.p.A.**  
 Via Conegliano, 73/B  
 31058 Susegana (TV) - Italy  
 Tel. Domestic Sales +39.0438.454294  
 Tel. Export Sales +39.0438.454290  
 Fax +39.0438.62788  
[www.htspa.it](http://www.htspa.it) - [htspa@htspa.it](mailto:htspa@htspa.it)

La ditta costruttrice declina ogni responsabilità per possibili inesattezze contenute nella pubblicazione, se imputabili ad errori di stampa.

Si riserva peraltro il diritto di apportare senza preavviso quelle modifiche che riterrà necessarie o utili ai fini del miglioramento del prodotto.

*The manufacturer disclaims all responsibilities for any inaccuracy, due to misprints, that may appear in this publication. He also reserves the right to make at any time all the modifications he will deem necessary to improve his products without notice.*

